

WSD C 150 KD

TECHNICAL DATA

- **Flow:** 150 l/min
- **Max working pressure:** 350 bar
- **Materials:** Cartridge in Steel Zinc Plated
- **Version:** Spool Type - Pilot Operated
- **Cavity:** FW0103000
- **Installation torque:** 60 Nm
- **Adjustable pressure range:** 10-200 bar
- **Weight:** 0,300 kg

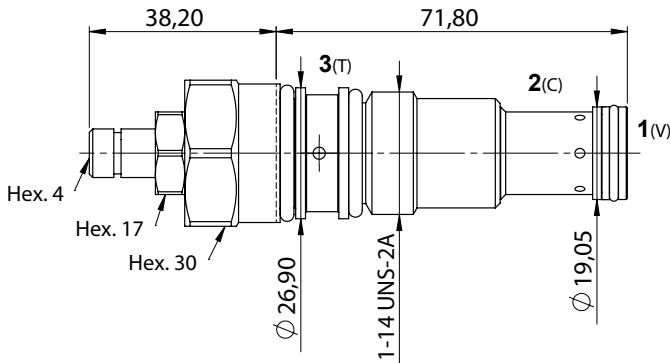
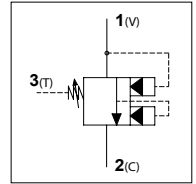

PRESSURE DROP CURVES

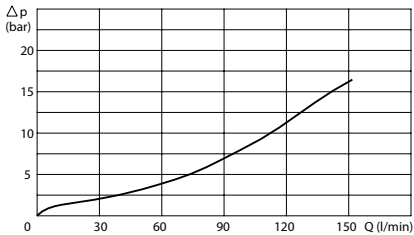

ORDERING CODE

WSD

C

150

KD