

WODSFC 30 - 2F

TECHNICAL DATA

- Flow:** 30 l/min
- Max setting pressure:** 350 bar
- Materials:** Steel Body
- Pilot ratio:** 4:1 (if request 8:1; 11:1)
- Weight:** 1,950 kg

- Note:** - Pressure setting must be 30 % higher that pressure induced by the load.
- Recommended for use with closed center spools.

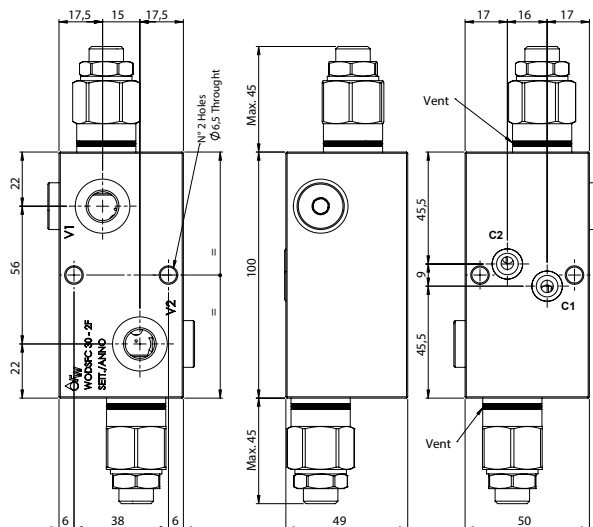
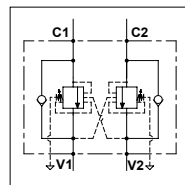

PORTS	
V1 - V2	1/4
C1 - C2	ø5

Possibility 3/8 ports.
Please contact our sales department.

PRESSURE DROP CURVES

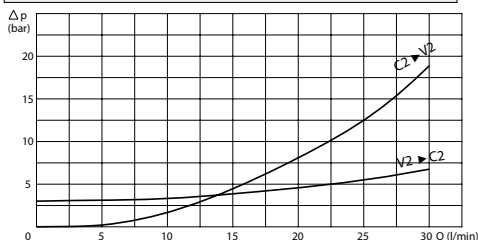

SPRINGS

Code	20			35		
	Adjustable pressure range bar	Pressure increase bar/turn	Standard setting bar	Adjustable pressure range bar	Pressure increase bar/turn	Standard setting bar
4:1	60-210	70	170	80-350	120	280
8:1	60-220	50		100-350	85	
11:1	60-250	90		80-350	150	

ORDERING CODE

WODSFC

30

2F

Ports Size:

- 1/4
- 3/8

Springs:

- 20
- 35

Pilot Ratio:

- Omit if 4:1
- 8 = 8:1
- 11 = 11:1

Adjustment if Required:

- Omit if not required
- Value