

WBD 20C - VP

TECHNICAL DATA

- **Flow:** See table
- **Max working pressure:** 350 bar
- **Cracking pressure:** See table
- **Materials:** Steel body
- **Pilot ratio:** 5,5:1
- **Weight:** See table

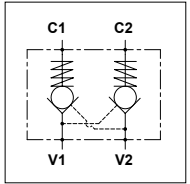

PORTS			
V1 - V2	1/4	1/4	3/8
C1 - C2	10L	12L	12L
DIMENSIONS			
A	128	131	135
B	68	64	68
C	38	36	38
Hex.	19	22	22
Max Flow (l/min)	20	20	30
Cracking Pressure (Bar)	7	4	4
Weight (kg)	0,680	0,650	0,630

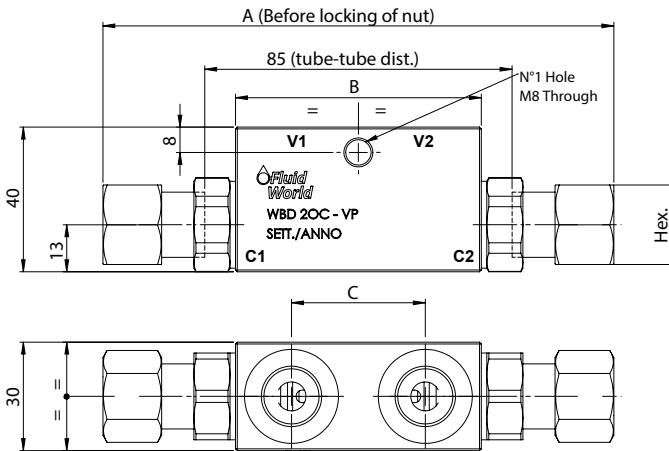

PRESSURE DROP CURVES

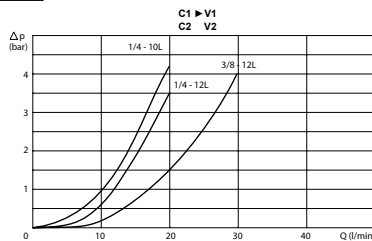
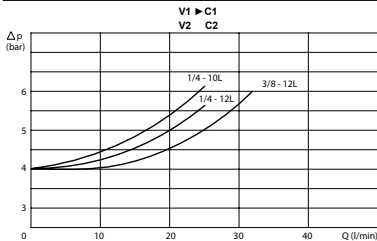

ORDERING CODE

WBD

20C

VP

Ports Size:

- 1/4
- 3/8

Size Pipe:

- Omit if 12 L
- 10 L (only for 1/4)